

Gauge Cock

All stainless steel



Features:

- Air vent hole for drain
- Working temperature up to 180°C
- Backelite cover on operating lever

Applications:

- Hydraulic machines
- Compressors & Process plants
- Clean air & Gases
- Non crystallised liquids

Standard Parameters:

- Body : AISI 316 SS
- Handle : AISI 304 SS with backelite cover
- Working pressure : 100 kg/cm²
- Working temperature : Up to 180°C
- Gasket seal : PTFE
- Connection : 1/2" BSP (F x F) for 2-way
- : 1/2" BSP (M x F x F) for 3-way

Dimensional Drawings

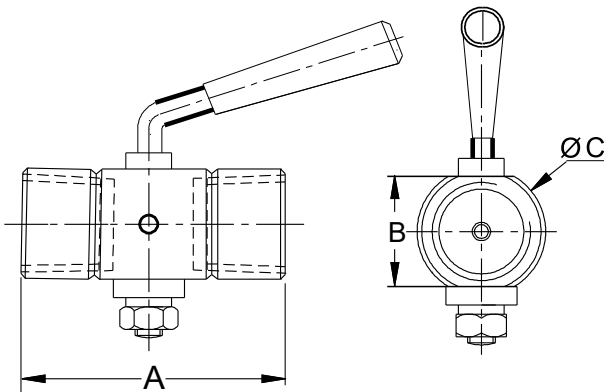

2-way					
Size	A			B	øC
	FxF	MxF	MXM		
1/4"	50	55	60	19	22
3/8"	55	60	65	25	28
1/2"	60	65	70	25	28

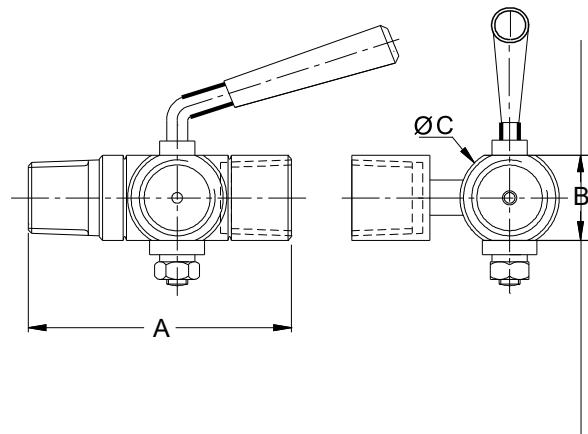

3-way				
Size	A		B	øC
	MxFXF			
1/4"	70	19	22	
3/8"	75	25	28	
1/2"	80	25	28	

Ordering codes

1. Type		2W	4. 3-way size & end Connection [inlet x outlet]		6B.6BF.6BF
2W	2-way			6B.6BF.6BF	
3W	3-way		6N.6NF.6NF	1/4" NPT (M x F x F)	
2. Body		S4	10B.10BF.10BF	3/8" BSP (M x F x F)	
S4	AISI 304 SS		10N.10NF.10NF	3/8" NPT (M x F x F)	
S6	AISI 316 SS		15B.15BF.15BF	1/2" BSP (M x F x F)	
			15N.15NF.15NF	1/2" NPT (M x F x F)	
3. 2-way size & end Connection [inlet x outlet]		6B.6BF	5. Options		MT
6BF.6BF	1/4" BSP (F x F)		OS	Oxygen service	
6B.6BF	1/4" BSP (M x F)		ML	Marking by laser	
6B.6B	1/4" BSP (M x M)		MT	Material test certificate	
10BF.10BF	3/8" BSP (F x F)		TH	Threaded hex plug for vent hole	
10B.10BF	3/8" BSP (M x F)				
10B.10B	3/8" BSP (M x M)				
15BF.15BF	1/2" BSP (F x F)				
15B.15BF	1/2" BSP (M x F)				
15B.15B	1/2" BSP (M x M)				
6NF.6NF	1/4" NPT (F x F)				
6N.6NF	1/4" NPT (M x F)				
6N.6N	1/4" NPT (M x M)				
10NF.10NF	3/8" NPT (F x F)				
10N.10NF	3/8" NPT (M x F)				
10N.10N	3/8" NPT (M x M)				
15NF.15NF	1/2" NPT (F x F)				
15N.15NF	1/2" NPT (M x F)				
15N.15N	1/2" NPT (M x M)				

Ordering Example: GC-2W-S4-6B.6BF-MT

Note: Specifications and dimensions given in this product catalogue represents the state of engineering at the time of printing. Modifications may take place and materials specified may be replaced by others without prior notice.