

Thermowell Bar stock screwed



Features:

- These thermowells are manufactured from solid bar stock and installed into the process with the help of threaded process connection.
- This design is suitable for all types of RTD's, thermocouples, mechanical as well as digital thermometer
- Available in various shapes

S - Straight

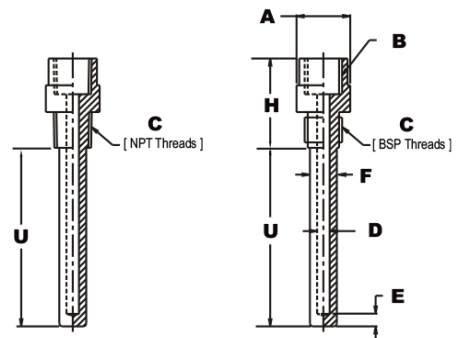

R - Reduced tip

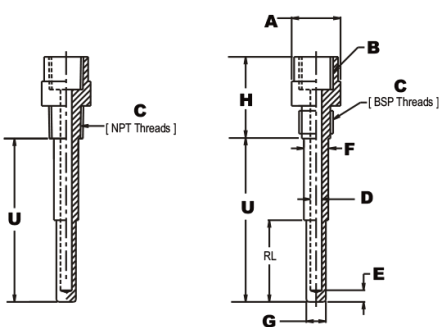

P - Partial taper

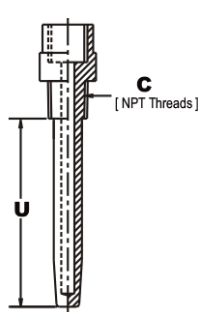

F - Full taper

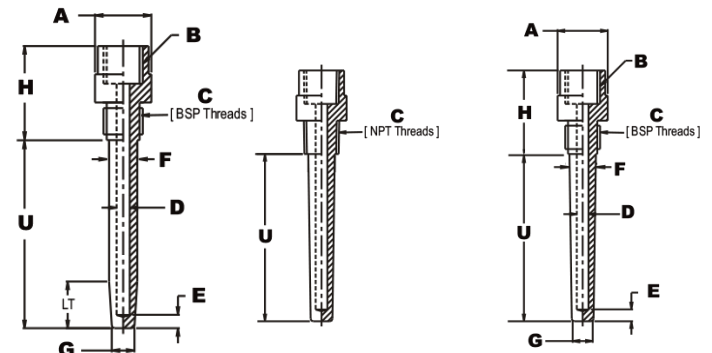

A - Finished head size
B - Instrument Connection
C - Process Connection
D - Bore Diameter

E - Tip thickness
F - Major diameter
G - Minor diameter
H - Extension length

U - Insertion length
RL - Reduced tip length
LT - Taper length

Ordering codes

1. Material		S6	5. Extension Length "H"	50mm
CS	Carbon steel		Please specify in mm	
S4	AISI 304 SS		6. Bore Diameter "D"	7mm
S6	AISI 316 SS (standard)		Please specify in mm	
S6L	AISI 316L SS		7. Major Diameter "F"	
MO	Monel		For S type Specify in mm	F22
I6	Inconel 600		Major Diameter "F"	OR
I8	Inconel 800		For e.g.: F22 for 22 mm	
Br	Brass		For R type Specify in mm	F22
HC	Hest alloy C		Major Diameter of step "F"	-G18
HB	Hest alloy B	For e.g.: F22 for 22 mm	-RL100	
TI	Titanium	Minor Diameter of step "G"		
TA	Tantalum	For e.g.: G18 for 18 mm		
NI	Nickel	Length of step "RL"	OR	
		For e.g.: RL100 for 100 mm		
2. Instrument Connection "B"		15BF	For P type Specify in mm	F22
10BF	3/8" BSP[F]		Major Diameter of Taper "F"	-G18
10NF	3/8" NPT[F]		For e.g.: F22 for 22 mm	-LT150
10BTF	3/8" BSPT[F]		Minor Diameter of Taper "G"	
15BF	1/2" BSP[F]		For e.g.: G18 for 18 mm	OR
15NF	1/2" NPT[F]		Length of Taper "LT"	
15BTF	1/2" BSPT[F]		For e.g.: LT150 for 150 mm	
20BF	3/4" BSP[F]		For F type Specify in mm	F22
20NF	3/4" NPT[F]		Major Diameter of Taper "F"	-G18
20BTF	3/4" BSPT[F]		For e.g.: F22 for 22 mm	
M18F	M18 x 1.5[F]	Minor Diameter of Taper "G"		
M20F	M20 x 1.5[F]	For e.g.: G18 for 18 mm		
	* Without capillary option			
3. Process Connection "C"		10B	8. Tip Thickness "E"	5mm
10B	3/8" BSP[M]		Standard Tip thickness is 5 mm	
10N	3/8" NPT[M]		For others, please specify in mm	
10BT	3/8" BSPT[M]		9. Insertion Length "U"	250mm
15B	1/2" BSP[M]		Please specify in mm	
15N	1/2" NPT[M]		10. Options	LM
15BT	1/2" BSPT[M]		TG	SS tag plate
20B	3/4" BSP[M]		PG	Plug & chain in SS
20N	3/4" NPT[M]		LM	Laser Marking
20BT	3/4" BSPT[M]			
M20	M20 X 1.5[M]			
4. Finished Head Size "A"		28mm		
Please specify in mm				

Ordering Example: T1-S6-15BF-10B-28mm-50mm-7mm-F22-G18-LT150-5mm-250mm-LM

Note: Specifications and dimensions given in this product catalogue represents the state of engineering at the time of printing. Modifications may take place and materials specified may be replaced by others without prior notice.