



## Diaphragm seal Heavy duty mini seal

### Features:

- All AISI 316 SS construction
- Light weight
- Economical
- Ideal choice for high pressure
- The diaphragm is welded to the body to ensure separation of the filling fluid from the process medium.

### Applications:

- Diaphragm seals are designed to isolate the sensing element of pressure gauges and pressure switches from process fluids that they may be corrosive, viscous, sedimentous and / or with a high temperature.

### Standard Parameters

Seal type & Range	: T11 = -1 to 0 kg/cm <sup>2</sup> & 0 to 4 kg/cm <sup>2</sup>
	: T12 = 6 kg/cm <sup>2</sup> to 70 kg/cm <sup>2</sup>
	: T13 = 100 kg/cm <sup>2</sup> to 400 kg/cm <sup>2</sup>
	: T14 = 250 kg/cm <sup>2</sup> to 600 kg/cm <sup>2</sup>
Process temperature	: - 40 °C to 200 °C or as per fill fluid
Instrument connection	: 1/2" BSP[F]
	: 1/4" BSP[F] for type T14
Process connection	: 1/2" BSP[M]
	: 1/4" BSP[M] for type T14
Fill fluid	: Silicon Oil - DC 200
Mounting	: Direct (without capillary)

### Materials of Construction

Diaphragm	: AISI 316L SS
Body	: AISI 316 SS

### Dimensional drawing

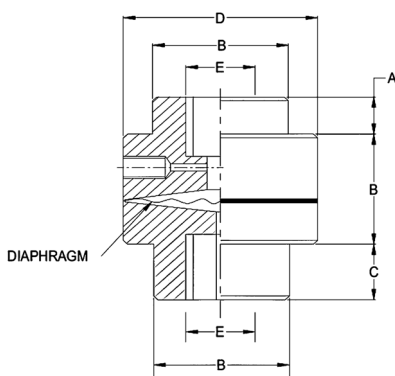

**Type T11 (Standard version)**

A	B	C	D	E	Wt.
10	30	10	34	1/4" BSP[F]	350

Wt. = Approx. weight in grams

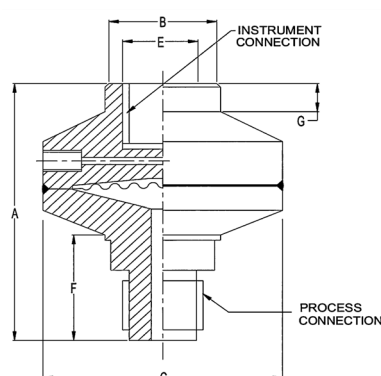

**Type T12**

A	B	C	E	F	G	Wt.
73	30	62	1/2" BSP[F]	30	8	700

Wt. = Approx. weight in grams

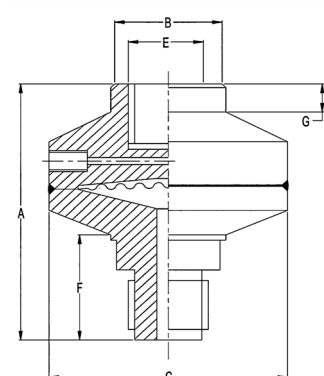

**Type T13**

A	B	C	E	F	G	Wt.
68.5	30	53	1/2" BSP[F]	35	8	600

Wt. = Approx. weight in grams

Note: ● Drawings are not to scale ● All dimensions are in mm

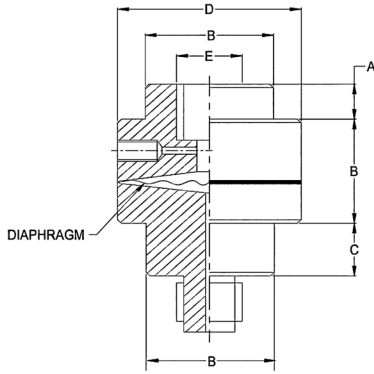

Type T14

A	B	C	D	E	Wt.
10	22	15	46.5	1/2" BSP[F]	400
Wt. = Approx. weight in grams					

Ordering codes

<p><b>1. Type</b></p> <p><b>T11</b> -1 kg/cm<sup>2</sup> to 0 &amp; 0 to 4 kg/cm<sup>2</sup> (Standard)  <b>T12</b> 6 kg/cm<sup>2</sup> to 70 kg/cm<sup>2</sup>  <b>T13</b> 100 kg/cm<sup>2</sup> to 400 kg/cm<sup>2</sup>  <b>T14</b> 250 kg/cm<sup>2</sup> to 600 kg/cm<sup>2</sup></p>	<b>T11</b>	<p><b>06NF</b> 1/4" NPT[F]  <b>06B</b> 1/4" BSP[M]  <b>15NF</b> 1/2" NPT[F]  <b>06N</b> 1/4" NPT[M]  <b>15N</b> 1/2" NPT[M]  <b>10B</b> 3/8" BSP [M]  <b>15B</b> 1/2" BSP [M]</p>	
<p><b>2. Instrument Connection</b></p> <p><b>06BF</b> 1/4" BSP[F]  <b>10BF</b> 3/8" BSP [F]  <b>15BF</b> 1/2" BSP [F](Standard)  <b>15NF</b> 1/2" NPT [F]  <b>06NF</b> 1/4" NPT [F]</p>	<b>15BF</b>	<p><b>7. Filling Fluids</b></p> <p><b>S1</b> Silicon DC 200 [-40 to 205°C]  <b>S2</b> Silicon DC 704 [10 to 337°C]  <b>S3</b> Silicon DC 710 [7 to 371°C]  <b>FG</b> Food Grade Oil [-20 to 140°C]</p>	<b>S1</b>
<p><b>3. Top Chamber</b></p> <p><b>S4</b> AISI 304 SS (Standard)  <b>S6</b> AISI 316 SS  <b>S6L</b> AISI 316L SS</p>	<b>S6</b>	<p><b>8. Remote Mounting*</b></p> <p>Specify in Meters                      *with capillary of max up to 2 Meters</p>	<b>1M</b>
<p><b>4. Diaphragm</b></p> <p><b>S6L</b> AISI 316L SS (Standard)  <b>MO</b> MONEL  <b>HC</b> Hastelloy 'C'</p>	<b>S6</b>	<p><b>9. Capillary</b></p> <p><b>S4</b> AISI 304 SS  <b>S6</b> AISI 316 SS</p>	<b>S6</b>
<p><b>5. Bottom Chamber</b></p> <p><b>S6</b> AISI 316 SS (Standard)  <b>S6L</b> AISI 316L SS  <b>MO</b> MONEL  <b>HC</b> Hastelloy 'C'</p>	<b>S6</b>	<p><b>10. Capillary covered with armour*</b></p> <p><b>S4</b> AISI 304 SS  <b>S6</b> AISI 316 SS  <b>PV</b> PVC (Ambient Temp. Max. 60°C)                      *Applicable with capillary option if applied</p>	<b>S6</b>
<p><b>6. Process Connection</b></p> <p><b>06BF</b> 1/4" BSP[F]  <b>10BF</b> 3/8" BSP[F]  <b>15BF</b> 1/2" BSP[F]</p>	<b>15B</b>	<p><b>11. Other Options</b></p> <p><b>HL</b> Helium leak test  <b>WI</b> Dry Seal Only Without Instrument  <b>MT</b> Material Test Certificates*                      *Material test certificates will be provided for wetted parts only.</p>	<b>MT</b>

Ordering example: HD-T11-15BF-S6-S6-S6-15B-S1-1M-S6-S6-MT

Compatible Model: IP, IE

Note:

- It is recommended that the MOC of the diaphragm be equivalent or superior than the MOC of the bottom chamber.
- Specifications and dimensions given in this product catalogue represents the state of engineering at the time of printing. Modifications may take place and materials specified may be replaced by others without prior notice.