

Mini Hygienic Gauge (Triclamp Connection)



Features:

The Mini Hygienic Gauge is a 63mm pressure gauge fitted with a 3/4" Triclamp diaphragm seal.

Applications:

This Gauge was designed to address the growing number of pharmaceutical applications which require a smaller hygienic gauge with 3/4" Triclamp connection.

Standard Parameters:

Dial Size	: 63 mm
Case & Ring	: SS 304, Bayonet type
Protection	: IP-65
Window	: Acrylic
Movement	: SS 304
Dial	: Aluminium black Numericals on white
Pointer	: Aluminium Black Painted
Bourdon	: SS 316 L
Socket	: SS 316
Standard	: EN 837-3
Mounting	: Direct Bottom
Range	: 6, 10, 16, 20 kg
Process Temperature	: -3° to 121°C
Ambient Temperature	: -4° to 49°C
Instrument Connection	: 1/4" BSP[F]
Process Connection	: 3/4" Triclamp
Fill Fluid	: Glyceine (Optional)
Accuracy	: 1.6% of FSD
Diaphragm MOC	: SS 316L

Dimensional Drawing

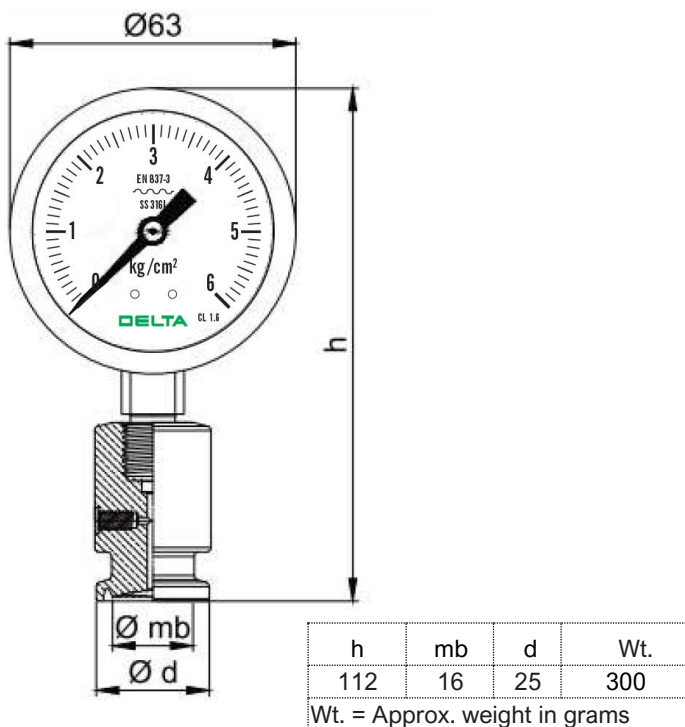

Note: ● Drawing is not to scale ● All dimensions are in mm

Ordering codes

1. Body material		S6
CS	Carbon Steel	
S6	SS 316	
S4	SS 304	
Mo4	Monel 400	
Mo5	Monel 500	
HC	Hastelloy C	
2. Fill Fluid		LG
LG	Liquid Glycerine	
SI	Silicon Oil	
3. Options		MT
MT	Material test certificate	
HG	Hydro test Certificate	
4. Range		X kg
X kg	X kg	

Ordering Example: MH-S6-LG-MT-6Kg

Note: Specifications and dimensions given in this product catalogue represents the state of engineering at the time of printing. Modifications may take place and materials specified may be replaced by others without prior notice.