

DIAPHRAGM SEAL FLUSH SANITARY TYPE

DSFS

Applications :

DIAPHRAGM SEALS ARE PROVIDED IN THE INSTRUMENTS LIKE PRESSURE GAUGES, SWITCHES, TRANSMITTERS IN ORDER TO ISOLATE THE SENSING ELEMENT FROM THE MAIN SERVICE DUE TO ITS CORROSIVE, VISCOUS AND SEDIMENTED NATURE AND TO AVOID CLOGGING AND SOLIDIFICATION. THESE SEALS ARE SPECIALLY DESIGNED FOR APPLICATIONS WHERE HIGH PURITY IN THE PROCESS IS ESSENTIAL.- TYPICALLY IN FOOD, BEVERAGES, DAIRY AND PHARMACEUTICAL INDUSTRIES.

Special Features :

- ★ ALL 316 STAINLESS STEEL
- ★ LASER WELDED FLUSH DIAPHRAGM
- ★ QUICK CONNECT / DISCONNECT FOR EASY CLEANING
- ★ MATCHING DIN, SMS, RJT ETC. STANDARDS
- ★ STD VERSION COMPATIBLE WITH DELTA MODEL IP FOR NS 50 TO 150MM



Specifications

Range	Refer range table with Nominal Sizes
Process Temperature	10°C to 150°C or as per fill fluid
Instrument Connection	½" BSP (F)
Process Connection	As per DIN 11851, SMS, RJT, IDF
Mounting	Direct (Without capillary)
Diaphragm	AISI 316L SS
Unit Nut	AISI 316 SS
Body	AISI 316 SS
Fill Fluid	Glycerin



Dimension :

DIN 11851		
DN	M	F(DIN 405)
25*	20	Rd 52 x 1/6
32	30	Rd 58 x 1/6
40	30	Rd 65 x 1/6
50	40	Rd 78 x 1/6

* Connection 1/4" BSP (F)

SMS		
DN	M	F(DIN 405)
1 ½"	30	Rd 60 x 1/6
2"	40	Rd 70 x 1/6

RJT/APV		
DN	M	F (Whitworth)
1 ½"	30	2" 5/16 x 8
2"	40	2" 7/8 x 6

IDF/ISS		
DN	M	F(ACME)
1 ½"	29	2" 1/32 x 8
2"	36	2" 9/16 x 8

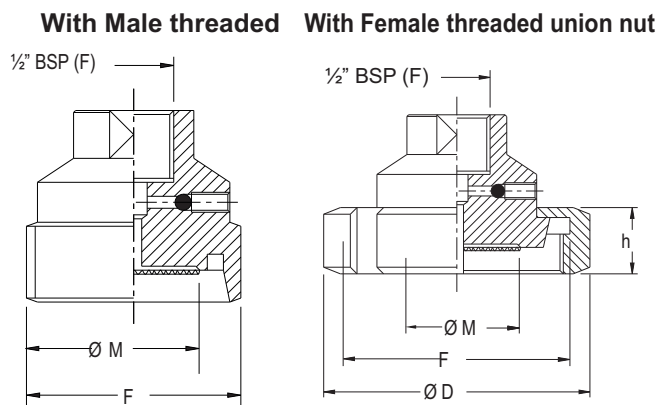

DIN 11851				
DN	h	D	M	F(DIN 405)
25*	21	63	30	Rd 52 x 1/6
32	21	70	30	Rd 58 x 1/6
40	21	78	40	Rd 65 x 1/6
50	22	92	50	Rd 78 x 1/6

* Connection 1/4" BSP (F)

SMS				
DN	h	D	M	F(DIN 405)
1 ½"	25	74	30	Rd 60 x 1/6
2"	26	84	40	Rd 70 x 1/6

RJT/APV				
DN	h	D	M	F (Whitworth)
1 ½"	22	Hex. 65	30	2" 5/16 x 8
2"	22	Hex. 79	40	2" 7/8 x 6

IDF/ISS				
DN	h	D	M	F(ACME)
1 ½"	30	64	30	2" 1/32 x 8
2"	30	77	40	2" 9/16 x 8

All Dimensions are in mm, Drawings are not to scale

RANGE TABLE WITH NOMINAL SIZES

Nominal Size of Gauge	50 & 63 mm	50 & 63 mm	50, 63, 100 & 150 mm	50, 63, 100 & 150 mm
Connection Standard	DIN/ IDF/ ISS	DIN/ IDF/ ISS/ SMS/ RJT	DIN/ IDF/ ISS/ SMS/ RJT	DIN
Connection Size	25 mm (1")	32 mm (1.5")	40 mm (2")	50 mm
Ranges (bar)				
1.6	U	U	U	U
2	U	U	U	U
4	U	U	U	U
7	U	U	U	U
10	U	U	U	U
14	U	U	U	U
16	U	U	U	U
21	U	U	U	U
25	V	V	U	U
28	V	V	U	U
40	V	V	U	U
-1 to 4	V	U	U	U
-1 to 7	V	U	U	U
-1 to 10	V	U	U	U
-1 to 14	V	U	U	U
-1 to 21	V	U	U	U

HOW TO ORDER

BASIC MODEL

CODE

OPTIONAL EXTRAS

PROCESS CONNECTION TYPE

M WITH MALE THREADED CONNECTION

F WITH FEMALE THREADED UNION NUT

PROCESS CONNECTION STANDARD & SIZE

KH DIN (25, 32, 40 OR 50 mm)

KJ RJT/APV (1½" OR 2")

KI SMS (1½" OR 2")

KK IDF / ISS (1½" OR 2")

(Example - Write KH DIN 25)

INSTRUMENT CONNECTION

6B 1/4" BSP (F) (Standard for DIN 25 & NS 50 & 63 mm)

6N 1/4" NPT (F)

15B ½" BSP (F)(Standard)

15N ½" NPT (F)

DIAPHRAGM

S6L AISI 316L SS (Standard)

FILLING FLUIDS

UF GLYCERIN [10 to 150°C / 50 to 302°F](Standard)

UG LIQUID PARAFFIN [10 to 200°C / 50 to 392°F]

UV FOOD GRADE OIL [-20 to 140°C / -4 to 284°F]

BODY

S6 AISI 316 SS (Standard) **S6L** AISI 316L SS

OPTIONS

GASKET (SEALING RING)

FA DIN (25, 32, 40 OR 50 mm)

FC RJT/APV (1½" OR 2")

FB SMS (1½" OR 2")

FD IDF / ISS (1½" OR 2")

GASKET (SEALING RING) MATERIAL

VU SILICON (Standard) **VI** PTFE

BOTTOM MATING PART (MALE OR FEMALE)

KLM DIN (25, 32, 40 OR 50mm) **KNM** RJT / APV (1½" OR 2") **KLF** DIN (25, 32, 40 OR 50mm) **KNF** RJT / APV (1½" OR 2")

KMM SMS (1½" OR 2") **KOM** IDF / ISS (1½" OR 2") **KMF** SMS (1½" OR 2") **KOF** IDF / ISS (1½" OR 2")

(Example - To select male part, write KLM DIN 25 & to select female part, write KMF SMS 1½")

REMOTE MOUNTING (With capillary of Max. Up to 2 Mtrs.)

SPECIFY IN METERS (e.g. 1.5 = 1.5 METERS 2.0 = 2 METERS)

CAPILLARY

PE AISI 304 SS

PG AISI 316 SS

CAPILLARY COVERED WITH ARMOUR (Applicable with PE or PG if selected)

PF AISI 304 SS

PH AISI 316 SS

PI PVC (Ambient Temp. Max. 60°C)

OTHER OPTIONS

TB HELIUM LEAK TEST **TC** DRY SEAL ONLY WITHOUT INSTRUMENT **GH** MATERIAL TEST CERTIFICATES*

* MATERIAL TEST CERTIFICATES WILL BE PROVIDED FOR WETTED PARTS ONLY WITH CHEMICAL COMPOSITION TESTING. FOR OTHERS, PLEASE CONSULT FACTORY.

Ordering Example: DSFS - M- KH 15N - S6L - UF- S6- FA - VU - KLM - 1Mtr. - PE - PF - GH

FOR OTHER OPTIONAL ITEMS, PLEASE CONTACT FACTORY FOR DELIVERY AND MINIMUM QUANTITY OF ORDER.

Note : Specifications and dimensions given in this product catalogue represents the state of engineering at the time of printing. Modifications may take place and materials specified may be replaced by others without prior notice.

Example

DSFS

M

KH

15N

S6L

UF

S6

FA

VU

KLM

1Mtr.

PE

PF

GH